

(See Instructions 1101-G00 for Installation, Operation and Maintenance)

Section	1101
Effective	June 2011
Replaces	July 2010

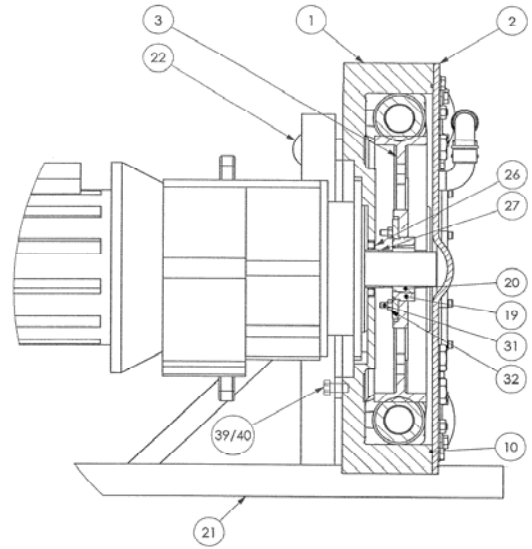

A-A

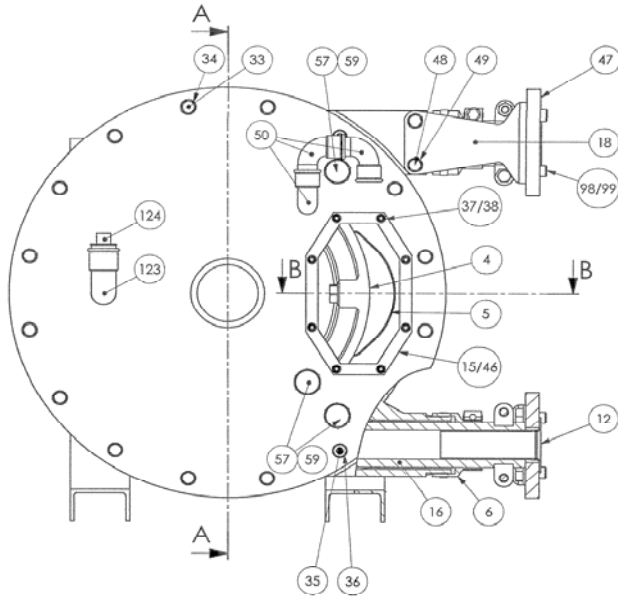
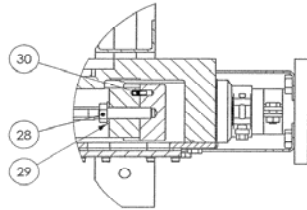
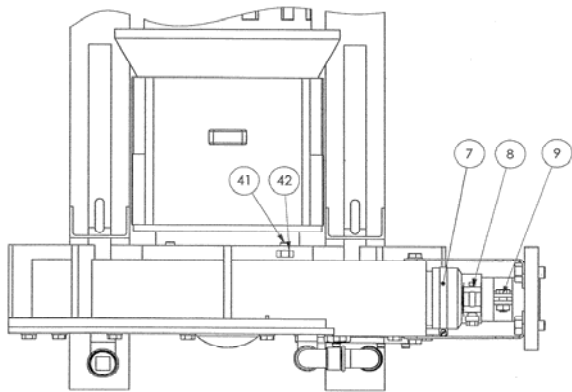

B-B

Reference			Description	Variants	Quantity		Article code	Wear parts
Ass.	Part	Available			Order	In Pump	AX40	
	3	▲	Wheel		1		217290	
	10	▲	Cover seal		1		220144	•
	12	▲	Insert	Stainless steel	1	2	217313	
	12	▲	Insert	PPH	1	2	217314	
	12	▲	Insert	PVDF	1	2	217315	
	1100	▲	Lubricant - Glycerin	5 liters	1		314222.00	•
	1100	▲	Lubricant - Glycerin	10 liters	1		314223.00	•
	15	▲	Window		1		220143	
	16	▲	Hose	NR	1		218730	•
	16	▲	Hose	NBR	1		218731	•
	16	▲	Hose	EPDM	1		218732	•
	18	▲	Bracket		1	4	219097	
	20	▲	Hub	Shaft diameter 48	1		217658	
	20	▲	Hub	Shaft diameter 50	1		217394	
	46	▲	Window seal		1		217396	
114	4	◆	Set of shims Removable shim		1	(12)	312359.00	
116	19 31 32	◆	Wheel fixation kit Plate to be screwed Screw Nut		1	(1) (6) (6)	313031.00	
118	6 7 8 9	◆	Boot + Hose clamp Nipple Hose clamp Hose clamp Hose clamp		1	(2) (2) (2) (2)	312745.00	

Reference			Description	Variants	Quantity		Article code	Wear parts
Ass.	Part	Available			Order	In Pump	AX40	
119		◆	Aluminum shoes + shims		1		312743.00	
119		◆	Iron shoes + shims		1		312744.00	
	4a		Fixed shim			(4)		
	4b		Fixed shim			(4)		
	5		Shoe			(2)		
	30		Pin			(2)		
125		◆	Shaft seal + bushing	Shaft diameter 48	1		313032.00	
125		◆	Shaft seal + bushing	Shaft diameter 50	1		313033.00	
	26		Shaft seal			(2)		
	27		Seal ring			(2)		
130		◆	Puncture detection kit		1		311840.00	
	50		Elbow			(1)		
	71		Fitting			(1)		
	72		Tee			(1)		
	73		Elbow			(1)		
	76		Fitting			(1)		
	77		Connector			(1)		
	78		Capacitive detector			(1)		
130		◆	Puncture detection kit ATEX		1		313739.00	
	50		Elbow			(1)		
	71		Fitting			(1)		
	72		Tee			(1)		
	73		Elbow			(1)		
	76		Fitting			(1)		
	77		Connector			(1)		
	78		Capacitive detector			(1)		
	84		Amplifier			(1)		

(◆) To order the required spare parts, indicate the appropriate CUM numbers.

Keep this parts lists with Installation, Operation and Maintenance Instructions.

CVT : FEP encapsulated FKM



Z.I. la Plaine des Isles - 2 rue des Caillottes F-89000 AUXERRE - FRANCE

Tel : +33 (0)3 86 49 86 30 • Fax : +33 (0)3 86 49 87 17

contact@mouvex.com • www.mouvex.com